

# COURSE OBJECTIVES

## CHAPTER 6

### 6. SHIP STRUCTURES

1. Qualitatively describe how shear stress is created in a ship structure.
2. Qualitatively describe the effect of shear stress on a ship structure.
3. Qualitatively describe why longitudinal bending is created in a ship structure.
4. Qualitatively describe the effect of longitudinal bending moments on a ship structure.
5. Define hogging and sagging.
6. Identify waves which can increase hogging and sagging.
7. Define the neutral axis of a structural cross section and know its significance to bending stress.
8. Use the elastic flexure formula to describe the distribution of bending stress in a section.
9. Be qualitatively familiar with hull-superstructure interaction, including the use of expansion joints.
10. Identify the following structural components:
  - a. Keel
  - b. Plating
  - c. Frame
  - d. Floor
  - e. Longitudinal
  - f. Stringers
  - g. Deck Beams
  - h. Deck Girders
11. Be familiar with the basic purposes, advantages and disadvantages of transverse and longitudinal framing elements.
12. Describe what constitutes a double bottom.

13. Be qualitatively familiar with the following modes of structural failure:
- a. Tensile/Compressive Yield
  - b. Buckling
  - c. Fatigue
  - d. Brittle Fracture

## 6.1 Unique Aspects of Ship Structures

Ship structures are unique in many ways:

- Ships can be gargantuan in their proportions. A *Nimitz* class aircraft carrier displaces about 97,000 LT, and is roughly 1115 ft by 252 ft.
- The loads these structures are subjected to are dynamic and random. Loads may range from small equipment vibrations to extreme wave impacts on the hull. Cargo weight and distribution also play a significant role in the structural requirements and response of a ship.
- The outer skin and supporting structure are multi-purpose. They not only keep the water out, but also subdivide the interior, act as a cargo carriage, and enhance safety.
- Unlike a building, a ship structure is a complicated three dimensional shape. The shape is determined more by resistance, powering, and internal arrangement considerations than by the desire to optimize the structure's shape for load carrying capability.
- Furthermore, ship structures are designed in the face of uncertainty in both demand and capability. The environment in which the ship will operate and the actual operational profile the ship will follow are usually unknown when the ship is designed and built. The precise material properties over time, the quality of workmanship during construction and maintenance, the shortcomings of analytical models, and the random nature of some failure modes (fatigue, corrosion) present the designer additional dilemmas.
- Naval ships operate in a combat environment. They must be able to resist underwater explosions, gunfire, blasts and projectiles. The shock produced by a ship's own weapons (16 inch guns, rockets) and nuclear air blast loading must factor into the design as well.
- In the face of all these requirements, considerations and uncertainties, a ship structure must also be lightweight, not take up space needed for other things, and cost as little as possible.

## 6.2 Ship Structural Loads

### 6.2.1 Distributed Forces

So far in this course we have considered the 2 principle forces associated with weight and buoyancy of a ship to be the resultant forces of Displacement ( $\Delta_s$ ) and the Buoyant Force ( $F_B$ ). These forces pass through the 2 centroids of the center of gravity (G) and center of buoyancy (B) respectively. Provided  $\Delta_s$  and  $F_B$  are equal in magnitude and the centroids G and B are vertically in line, the vessel is said to be in a state of static equilibrium. Figure 6.1 shows this situation.

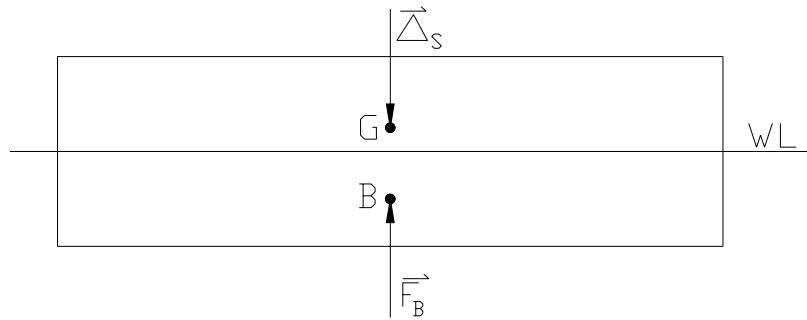

Figure 6.1 – Floating Body in Static Equilibrium

In fact, this representation is a convenient approximation to the true situation on a ship.  $\Delta_s$  and  $F_B$  are the resultant forces associated with 2 distributed forces along the length of a ship.

#### 6.2.1.1 Distributed Buoyancy

In structural analysis, it is convenient to consider the buoyant force ( $F_B$ ) as a distributed force. This is often displayed diagrammatically as in Figure 6.2.

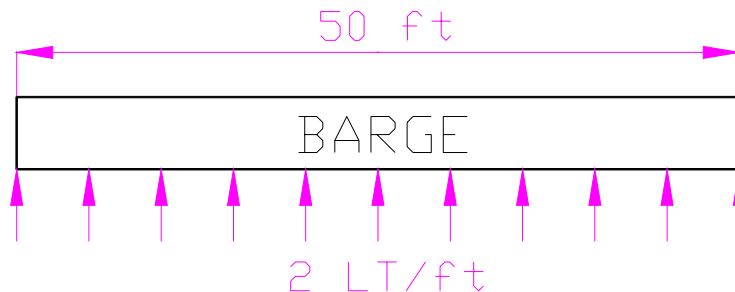

Figure 6.2 – Box Shaped Barge with Distributed Force

Figure 6.2 represents a uniformly distributed buoyant force. This type of distribution is very rare and would be associated with a box-shaped barge floating at level trim.

ⓘ Despite its rarity, this simple distribution pattern will be used in this course to represent the distributed buoyant force.

It is a fairly straightforward calculation to determine the overall buoyant force represented at Figure 6.2. The figure shows a force of 2 LT/ft over a 50 ft long barge. Hence:

$$F_B = 2 \frac{LT}{ft} \cdot 50ft = 100LT$$

### 6.2.1.2 Distributed Weight

In a similar manner to the buoyant force, the weight of a vessel is more accurately represented as a distributed force along its length. For example, the box shaped barge described at Figure 6.2 could also have a uniformly distributed weight down its length. It is evident that to place the barge in static equilibrium, the magnitude of this force would have to match the magnitude of the distributed buoyant force. Figure 6.3 displays this situation.

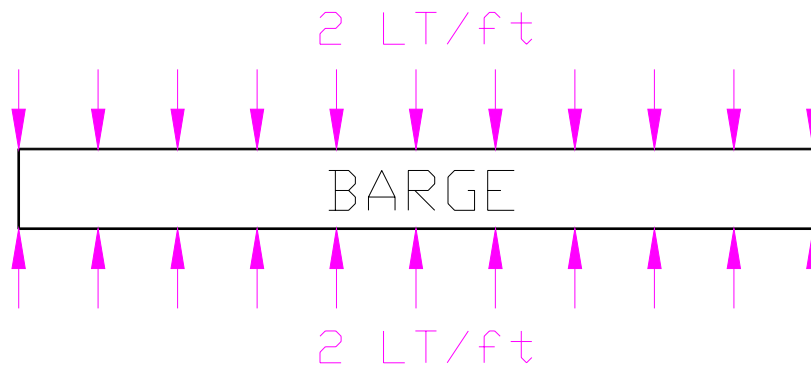

Figure 6.3 – Box Shaped Barge with Distributed Buoyant Force and Displacement

Calculations similar to that for the buoyant force can be performed to reveal the magnitude of the resultant Displacement ( $\Delta_s$ )

$$\Delta_s = 2 \frac{LT}{ft} \cdot 50ft = 100LT$$

In practice, the weight of a vessel is not uniformly distributed. Elements of a ship such as engines, cargo and superstructure often provide an uneven distribution of weight along a vessels length. For example, the box shaped barge carrying cargo in its center holds could have a distribution as described at Figure 6.4.

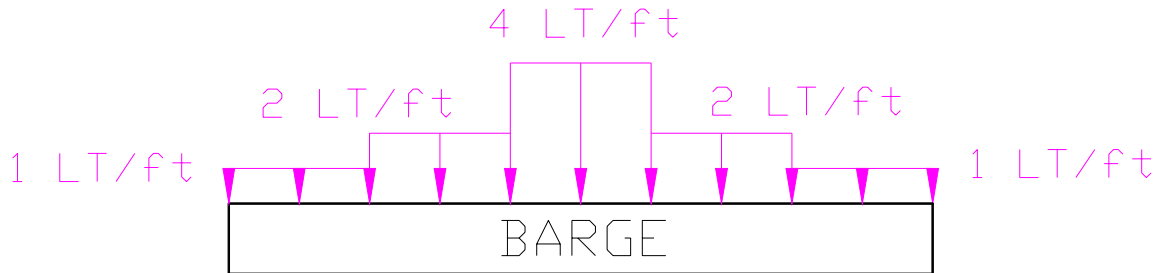

Figure 6.4 – Realistic Weight/Displacement Distribution

As before, the resultant displacement ( $\Delta_s$ ) can be calculated.

$$\Delta_s = \left[ \frac{1}{5} \cdot \frac{1LT}{ft} + \frac{1}{5} \cdot \frac{2LT}{ft} + \frac{1}{5} \cdot \frac{4LT}{ft} + \frac{1}{5} \cdot \frac{2LT}{ft} + \frac{1}{5} \cdot \frac{1LT}{ft} \right] \cdot 50ft$$

$$\Delta_s = 100LT$$

To achieve static equilibrium, the magnitude of the buoyant force  $F_B$  would have to equal this displacement. Consequently, the overall distributions of both displacement and buoyancy for the box shaped barge would be as depicted in Figure 6.5.

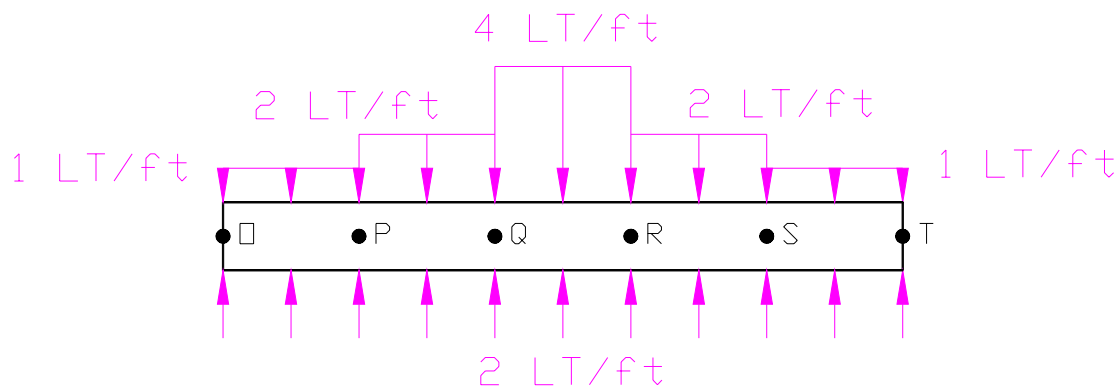

Figure 6.5 – Overall Buoyancy and Displacement Distributions

## 6.2.2 Shear Stress

An analysis of the distributed forces on the box shaped barge at Figure 6.5 soon reveals the presence of significant shear stress at points P, Q, R, and S. This is easily acquired by summing the forces vertically at each point down the vessel to produce the overall force distribution as described at Figure 6.6. This is often referred to as the load diagram.

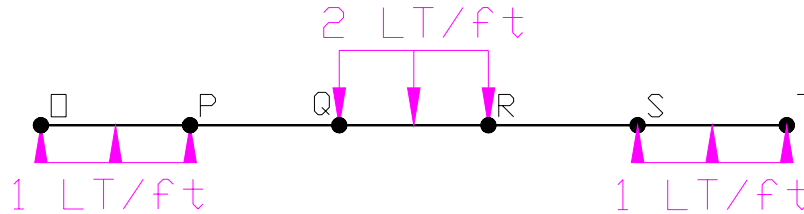

Figure 6.6 – The Load Diagram

Figure 6.6 clearly represents the shear planes being generated within the hull of the barge at these points.

### 6.2.2.1 Reducing Shear Stress

The effects described above could be minimized in 2 ways.

- The shape of the underwater hull of the barge could be altered so that its buoyancy distribution matched that of the weight distribution. There are 2 problems with this:
  - a. The step like shape would be very inefficient with regard to the resistance or drag force associated with the hull.
  - b. For a vessel such as the barge, the weight distribution will change every time a loading or unloading operation is performed.
- The hull's strength could be concentrated in areas known to be subjected to large shear forces.

This last method is obviously more feasible. An analysis as described above can easily identify areas of a ship where shear forces will be generated. Using higher strength materials or increasing the cross sectional area of the ship structure at these points will reduce the possibility of the structure failing due to shear.

### 6.2.3 Longitudinal Bending Stress

A further analysis of the load diagram at Figure 6.6 quickly reveals the presence of a bending moment being applied to the vessel. Figure 6.7 repeats the load diagram and shows this bending effect.

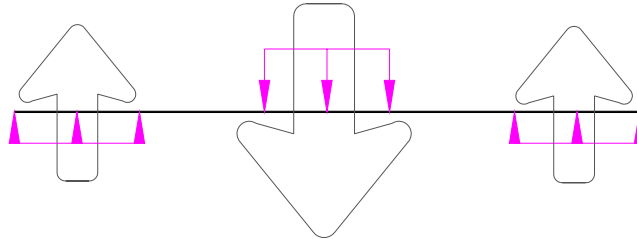

Figure 6.7 – Load Diagram Showing Longitudinal Bending

The greater concentration of buoyancy at the bow and stern, and the concentration of weight at the center has an overall effect attempting to bend the barge in the middle. The magnitude of the bending moment could be found by integrating the shear force over the length of the ship.

#### 6.2.3.1 Sagging

The force distribution at Figure 6.7 is making the barge appear to “sag” in the middle, consequently this bending condition is referred to as “sagging”. This condition is analogous to resting a ruler between 2 surfaces and pressing down on its middle.

It is fairly evident, that the “sagging” longitudinal bending condition is creating significant stresses in the structure termed bending stresses. The bending direction is stretching the lower portion of the structure, hence tensile stresses are being created in the keel region. Conversely, the weather deck is being placed in compression because the bending direction is trying to shorten this part of the structure.

#### 6.2.3.2 Hogging

A reversal of the overall weight distribution at Figure 6.7 would result in the opposite bending condition being created. This is called “hogging”. In this condition the overall weight is greatest near the bow and stern, with buoyancy being larger near midships. This has the effect of bending the structure in the other direction, placing the keel in compression and the deck in tension.



You may wish to use the analogy of carrying a pig over your shoulder to remember the term “hogging”!



### 6.2.3.3 Wave Effects

In addition to the still water effects described so far, the presence of waves can further increase the magnitude of bending stresses being created in a ship structure.

For example, if a ship is subjected to the wave shown at Figure 6.8 with crest at the bow and stern, the buoyant force will be concentrated more at the ends than in the middle, because less of the middle of the ship is underwater. The net effect is that the middle gets less support, the ends get more support, and the ship wants to sag in the middle, hence sagging.

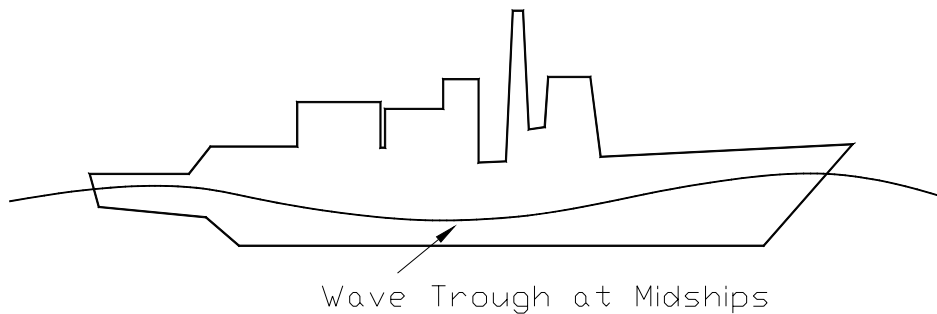

Figure 6.8 – Sagging in Waves

Conversely, if the wave crest is amidships, then a hogging condition will result. More of the underwater volume is concentrated amidships, increasing the upward forces there while the ends of the ship receive less support. Pushing up more in the middle can give the ship a negative curvature as shown at Figure 6.9.

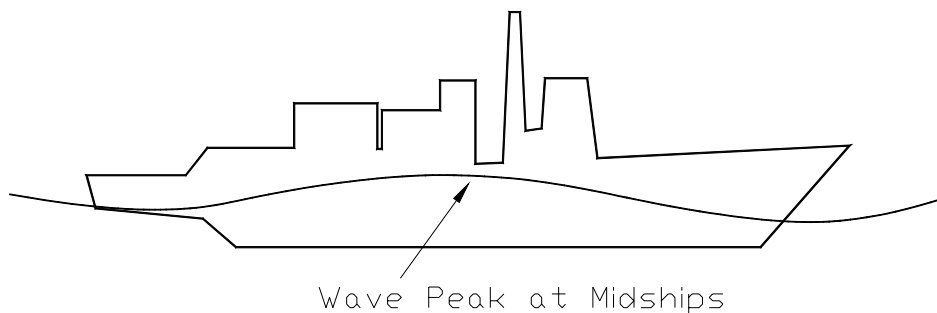

Figure 6.9 – Hogging in Waves

The worst case bending moments occur when the length of the ship is nearly equal to the length of the waves.

### 6.2.3.4 Quantifying Bending Stress

During the structural analysis of a ship it is important that the magnitudes of any bending stresses being created by sagging and hogging conditions can be quantified. In this analysis it is convenient to model the ship structure as a box shaped beam, all calculations can then be performed using simple beam theory.

Figure 6.10 shows the arrangement used to describe the sagging condition. As discussed previously, sagging creates a compression in the deck and tension in the keel.

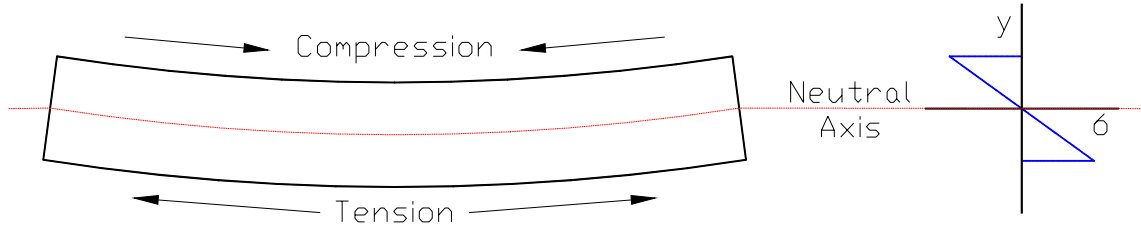

Figure 6.10 – Variation in Bending Stress Across a Sagging Beam

Obviously, there must be a transition between tension and compression in a section, this is called the neutral axis. The position of the neutral axis is easily found as it is also the geometric centroid of the cross section.

With the neutral axis found, the actual bending stresses being experienced by the ship structure are easily quantified by using the elastic flexure formula.

$$\text{Bending Stress } (\sigma) = \frac{My}{I}$$

where  $M$  = the bending moment in LT-ft. This can be found from an analysis of the overall load diagram such as that at Figure 6.6.

$I$  = the second moment of area of the cross section of the structure in  $\text{ft}^4$ . This is measured from the dimensions of the ship structure.

$y$  = the vertical distance from the neutral axis.

Figure 6.10 shows the variation in bending stress being created in the section of a ship at different distances from the neutral axis. Notice it is a linear relationship. By convention, compressive stress is negative and tensile stress is positive.

The bending stress is zero at the neutral axis where  $y = 0$  ft.

The bending stress is maximum at the deck and keel where  $y$  is at its largest.

**Student Exercise 6.1**      In the space below, redraw Figure 6.10 to show a ship structure in a hogging condition. Beside your drawing, sketch how the bending stress alters from the keel to the deck.

### 6.2.3.5 Reducing the Effects of Bending Stress

Clearly, bending stress is a major cause of concern in establishing a safe ship structure. Unfortunately, because the ship is designed to go to sea where it will experience wave action, there is no method of removing the presence of bending moments. However, an analysis as described above can allow the areas of the ship that will experience the greatest bending stresses to be determined.

Typically, bending moments are largest at the midship area of a ship. Also, because of the elastic flexure formula, it is clear that the keel and deck will experience the greatest magnitude of bending stress. Consequently, it is important that these areas have sufficient strength to combat these stresses. Higher strength steels are common in these regions, and the cross sectional area of longitudinal structural elements increases the as you move further from the neutral axis.

### 6.2.3.6 Hull - Superstructure Interaction

Due to its distance from the neutral axis, bending stresses in the superstructures of ships can be very large. Unfortunately, it is often undesirable to use high strength materials or structural elements with large cross sections in the superstructure due to the problems this could create with stability. Consequently, other methods of reducing stress must be found.

One solution is the use of expansion joints. The primary reason for using expansion joints involves the shear between the deck and the superstructure. If a ship is hogging, then the deck is under tension. The deck also makes the bottom of the superstructure curve by pulling it outward, or placing it in tension. This outward pull, or shear load, between the superstructure and the hull is aggravated by the sharp corners where the hull and superstructure connect. As a result, ships like those having *Spruance* class hulls (DD 963 class, CG 47 class) and the *Oliver Hazard Perry* (FFG 7) class experience cracking in these areas. This is also a potential problem for the *Arleigh Burke* (DDG 51) class destroyers.

Another solution is to break the superstructure up into short sections. However, this is often unsatisfactory in terms of space efficiency and ship habitability.



*USS Princeton* (CG 59) struck a mine during Desert Storm. As a result of the explosion and the large stresses placed on the hull, 10% of the superstructure separated from the main deck.

### 6.2.3.7 Actual Ship Bending Analysis (OPTIONAL)

Ships are designed to withstand stresses caused by being balanced on a wave of a particular length and height. In so-called standard strength calculations, the length of the wave is assumed to be equal to the length of the ship and the height is assumed to be  $L/20$  ft. Such standard calculations are performed assuming static conditions. The resulting stresses can therefore only be used as a basis of comparison between ships of similar types engaged in similar mission under similar conditions.

The resulting stresses in the ship are based on the maximum longitudinal bending moment derived from the graphical integration of the load curve. This load curve is obtained by plotting the algebraic difference between the weight and buoyancy at successive points along the length of the ship similar to that of Figure 6.6. However, instead of using a uniformly distributed buoyant force, the true buoyant force distribution is determined by an analysis of the change in submerged sectional area down the length of the ship.

## 6.2.4 Hydrostatic Loads

Another major source of loading on a ship is that associated with hydrostatic pressure. This force can be considerable, especially in submarines and submersibles, and is constantly attempting to crush the sides of a ship.

Calculation of the load associated with hydrostatic pressure is fairly straightforward as the pressure at any depth is given by the following.

$$P = P_{atm} + \rho gh$$

## 6.2.5 Torsional Loads

Torsional loads are often insignificant, but they can have an effect on ships with large openings in their weatherdeck. This is often desirable on merchant ships such as container vessels where large deck openings make for efficient space utilization and faster loading/unloading times.

## 6.2.6 Weapon Loads

For military ships, another major load can be created by the impact of explosions both in the air, underwater and directly against a ship structure. Ships must be designed and manufactured with sufficient strength to resist these forces.

To assess ship survivability after a weapon impact, military ships will often go through a series of “shock” trials during their sea trials. Recently, a whole series of shock trials at increasing levels of intensity were performed on a DDG 53 to assess current design practices and ship building methods.

## 6.2.7 Hull Deflection

You may have noted that up to this point no mention has been made about what type of material is used in the hull construction. Recall from section 6.2.3.4 that bending stress is solely a function of the applied moment and hull geometry. This is not to say that the choice of material is not important. In fact, the material characteristics, most notably, the Elastic Modulus (E) has a large impact on *how much* the hull bends under an applied moment. Under the same loading (i.e., bending moment) a more ductile material, such as aluminum will bend more than something less ductile, like steel. Again, the amount of deflection also depends upon the geometry of the hull.

$$\text{total hull deflection} \propto \frac{ML^2}{EI}$$

where:

- M = the maximum bending moment in LT-ft.
- I = the second moment of area of the cross section of the structure in ft<sup>4</sup>.
- E = the Elastic Modulus in LT/ft<sup>2</sup>
- L = the length of ship in ft

## 6.3 Ship Structure

A ship structure usually consists of a network of plates and supporting structure.

The supporting structure consists of large members running both longitudinally and transversely and is often known as the Frame. The ship plating is attached to the frame.

### 6.3.1 Structural Components

Figure 6.11 repeated from “Introduction to Naval Architecture” by Gilmer and Johnson shows the structural components listed below.

<b><i>Keel</i></b>	A large center plane girder running longitudinally along the bottom of the ship.
<b><i>Plating</i></b>	Thin pieces closing in the top, bottom, and sides of the structure. Plating makes a significant contribution to longitudinal hull strength, and resists the hydrostatic pressure load.
<b><i>Frame</i></b>	A transverse member running continuously from the keel to the deck. Resists transverse loads (ie - waves hitting the side of the ship)
<b><i>Floor</i></b>	Deep frames running from the keel to the turn of the bilge. Frames may be attached to floors - the frame would be that part above the turn of the bilge.
<b><i>Longitudinal</i></b>	Girders which run parallel to the keel along the bottom of the ship. Longitudinals intersect floors at right angles, and provide longitudinal strength.
<b><i>Stringers</i></b>	Girders running along the sides of the ship. Typically smaller than longitudinals, they also provide longitudinal strength.
<b><i>Deck Beams</i></b>	Transverse members of the deck frame.
<b><i>Deck Girders</i></b>	Longitudinal members of the deck frame.

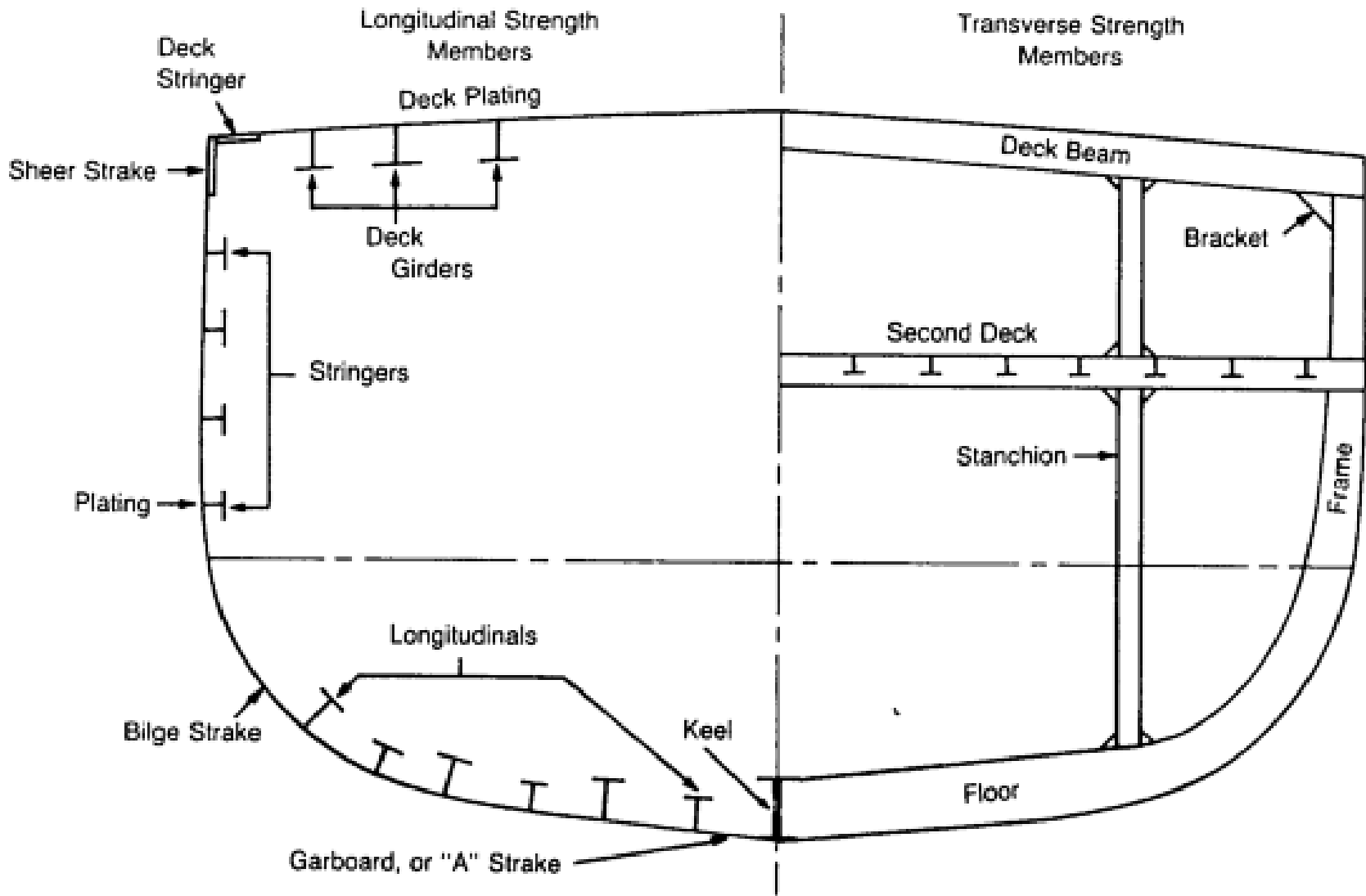

Figure 6.11 – Typical Transverse and Longitudinal Strength Members

## 6.3.2 Framing Systems

The number and size of the different framing elements used in the construction of a ship's frame is dependent upon a number of different factors. Clearly, it would be possible to make a ship very strong simply by adding more and more framing elements and increasing the thickness of its plating. However, this would make the ship increasingly inefficient in terms of space utilization and eventually cause it to sink when its displacement exceeded its possible buoyant force!

There has to be a compromise between the requirements of strength and the conflicting but equally important requirements of buoyancy, space utilization and cost. This compromise is to use an appropriate framing system to combat the types of load a particular ship is likely to encounter.

### 6.3.2.1 Longitudinal Strength Members

The longitudinal elements such as the keel, longitudinals, stringers and deck girders described in 6.3.1 have a primary role in combating the longitudinal bending stress created by the ship sagging and hogging. These conditions are maximized when the ship's length is equal to the wave length of a wave. A typical wave length associated with an ocean wave is about 300 ft; consequently, ships of this length and greater are likely to experience considerable longitudinal bending. Shorter ships experience much lower levels of bending because they tend to "terrain follow" a wave like a roller coaster.

Consequently, ships that are longer than about 300 ft tend to have a greater number of longitudinal elements to their structures than transverse elements. This is taken to extremes in very long ships where their structure is almost totally based upon longitudinal elements. A ship framed in this manner is said to be - *longitudinally framed*.

### 6.3.2.2 Transverse Strength Members

The transverse elements such as frames and hull plating have a primary role to combat the hydrostatic load. For ships shorter than 300 ft and those designed to operate at large depths, this is the primary load of concern. Hence short ships and submarines have structures consisting of many frames and fairly thick plating. A ship structured in this manner is said to be - *transversely framed*.



### 6.3.2.3 Combination Framing System

Modern Naval vessels typically use a *Combination Framing System* which combines the other two methods in some creative manner. A typical combination framing network might consist of longitudinals and stringers with shallow web frames. Every third or fourth frame would be a deep web frame. The purpose of such a system is to optimize the structural arrangement for the expected loading, while minimizing weight and cost.

### 6.3.3 Double Bottoms

Double bottoms are just that, two watertight bottoms with a void space in between. They are strong and can withstand the upward pressure of the sea in addition to the bending stresses. Double bottoms provide a space for storing fuel oil, fresh water (not potable), and salt water ballast. The structure can withstand considerable bottom damage caused by grounding or underwater blasts without flooding the ship provided the inner bottom remains intact. Also, a double bottom provides a smooth inner bottom. This makes it easier to arrange cargo and equipment while providing better accessibility for cleaning.

### 6.3.4 Watertight Bulkheads

The structural element that has not been mentioned so far is the watertight bulkhead. These are large bulkheads that split the hull of a ship into separate sections. In addition to their stiffening of the overall ship structure, they have a primary role in reducing the effects of damage on a ship.

Ships are designed so that they can withstand specified levels of damage before water creeps onto the weather deck. The rules for the damage stability of USN ships were covered in chapter 4. The careful positioning of these watertight bulkheads allows the ship to fulfill these rules and withstand certain damage conditions.

To enable watertight bulkheads to fulfill their role and withstand the pressures associated with flooded compartments, they are stiffened by steel members in the vertical and horizontal directions.

## 6.4 Modes of Structural Failure

In structural analysis, the word "failure" must be carefully defined. Sometimes it means total collapse, other times it means that a certain stress level is exceeded although only slight permanent damage occurs. A structure can be designed to withstand great punishment with virtually no damage, but cost and weight usually makes such a design unfeasible. The four basic modes of failure that we will consider are:

- Tensile or compressive yield
- Buckling/Instability
- Fatigue
- Brittle Fracture

### 6.4.1 Tensile or Compressive Yield

*“Slow plastic deformation of a structural component due to an applied stress greater than yield stress.”*

The failure criteria for many structures is that the yield stress shall not be exceeded, and that there shall be no permanent deformation resulting from a load. To ensure this does not occur, a factor of safety is applied during the design of a ship's structure so that the largest expected stress is only 1/2 or 1/3 of the yield strength. Because most Naval ships spend almost all of their service lives sagging, placing the bottom structure in tension, this is typically a criteria placed on bottom structure.

### 6.4.2 Buckling

*“An unstable condition caused by the compression of long slender columns resulting in substantial dimensional changes and a sudden loss of stiffness.”*

The compressive load at which a structure will buckle is called its buckling or bifurcation load. There are numerous equations available to calculate this value and by using factors of safety similar to those mentioned in 6.4.1, it should be possible to design structures that will not buckle. Unfortunately, many of the compressive loads delivered to a ships structure are very difficult to estimate. In particular, impact loads created by rough seas cause problems.

Buckling is influenced by the geometry of the component, the type of material used in the component, how the component is loaded, and how the component is being held in place with respect to the loading (called its end or boundary conditions). To illustrate, get a plastic ruler and stand it up on a table lengthwise. Push down on the ruler lengthwise and note how much compressive force it takes for the ruler to buckle. Now, do it again, but while you are pushing down on the ruler also push in on the flat side of the ruler. You should have seen that it took much less force to cause the ruler to buckle. Try it again it with someone rigidly holding the end of the ruler on the desk and see how that effects the buckling load. Also, try using a wooden or metal ruler. In all cases, you should have noted that the ruler remained in its elastic region (except for maybe the wood!) and returned to its original shape when it was unloaded.

Buckling is likely to occur on cross-stiffened deck panels on a ship due to large compressive stresses from longitudinal bending. Some *Ticonderoga* class cruisers have had problems with deck buckling.

### 6.4.3 Fatigue Failure

*“The failure of a material from repeated applications of stress, such as from vibration.”*

You will recall from chapter 5 that fatigue failure can occur even though the Yield Strength of the material is never exceeded. Figure 6.12 shows a plot of stress vs number of cycles required to cause failure. As the applied stress becomes lower, the number of cycles required increases until the curve flattens out. This flat region implies that applied stresses below a certain level will not cause failure at any number of cycles.

The *Endurance Limit* is the stress below which the material will not fail from fatigue. Steel exhibits the fatigue characteristics described. Aluminum, on the other hand, does not have an endurance limit. Aluminum structures, like the superstructures in some ships, must be designed to withstand a reasonable number of cycles over the expected life of the ship.

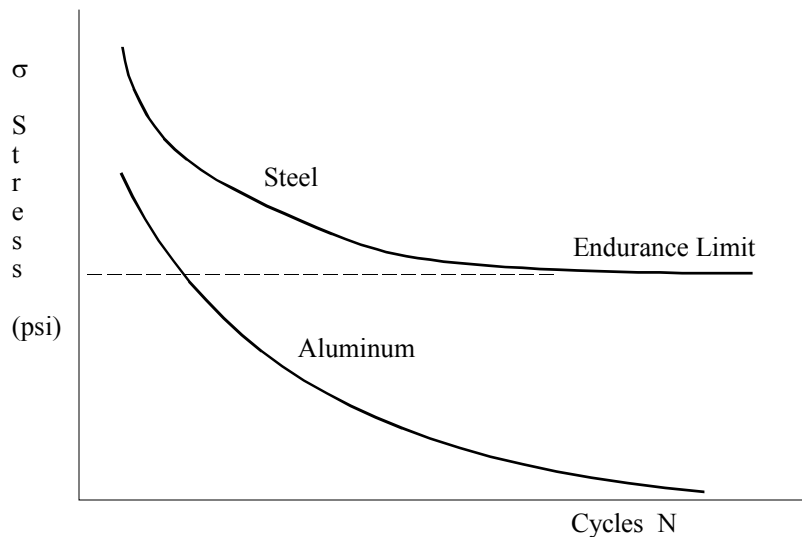

Figure 6.12 – Fatigue Characteristics

Fatigue failure in a real structure is greatly affected by such things as material composition (impurities, carbon content, internal defects), surface finish (smooth surfaces are best), environment (salt water is worse than air, moist air is worse than dry air), geometry (sharp corners and discontinuities are bad), and workmanship. All these will create stress concentrations. A stress concentration anywhere in a ship's structure that causes a localized stress to exceed the materials endurance limit will eventually cause a fatigue failure to occur.

The most common consequence of fatigue in ships is the development and propagation of cracks. If such cracks are not repaired, they can result in catastrophic failure.

#### 6.4.4 Brittle Fracture

*“the sudden catastrophic failure of a structure with little or no plastic deformation”*

As with Fatigue, the concepts of brittleness and toughness were also discussed in Chapter 5. The brittle fracture failure mode involves the rapid propagation of a small crack, often deep below the surface, into a large crack ultimately leading to fracture. The cracks are usually a consequence of fatigue. The risk of brittle fracture occurring depends on the material, temperature, geometry, and rate of loading.

- **Material** A material with low toughness is susceptible to brittle fracture. Low carbon steels are less brittle than high carbon steels. During the construction of the *Seawolf* hull, some welds were permitted to cool too rapidly, pinning carbon atoms in the wrong place within the metal's atomic structure. The resulting defects made the welds too brittle, and the work had to be scrapped and started over from the beginning. Poor welding practices were also the cause of the brittle fractures experienced by liberty ships during the early part of WWII.
- **Temperature** A material operating below its transition temperature is much more susceptible to brittle fracture because the toughness is very low. In 1954 the British ship *World Concord* brittle fractured and split up in the cold Irish Sea. Another interesting case occurred in Boston in 1919 when a 2,300,000 gallon molasses container brittle fractured, drowning 12 people and several horses.
- **Geometry** Cracks having sharp edges are worse than those which are rounded. A smaller crack is better than a big one. Even the orientation of the crack with respect to the loading is a factor. One of the quick methods of stopping the propagation of a crack is to “drill it out”, thereby reducing its edge sharpness.
- **Rate of Loading** Impact loads are more likely to cause brittle fracture than loads applied gradually and smoothly.

# HOMWORK CHAPTER 6

## Section 6.2

### Distributed Forces

1. An 80 ft rectangular, box-shaped barge is experiencing a uniformly distributed buoyant force of 4 LT/ft.
  - a. Calculate the resultant buoyant force.
  - b. At what point is the resultant buoyant force acting? Where is this point relative to the forward perpendicular?
  - c. Assuming the barge is in static equilibrium, what is its displacement?

### Longitudinal Bending

2. A loaded box-shaped barge has the following weight distribution. The barge is 120 ft in length.

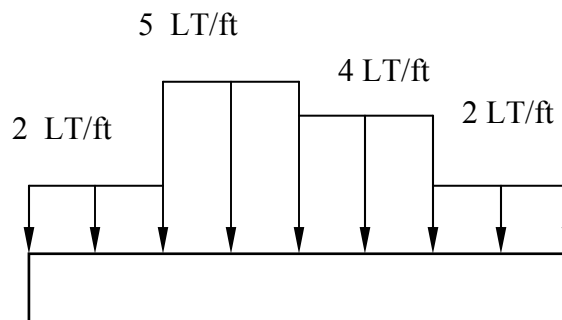

- a. Calculate the barge's displacement.
- b. Redraw the barge with the uniformly distributed buoyant force that would be required to place the barge in static equilibrium.
- c. Why can the buoyant force be considered to be uniformly distributed?
- d. Use your answer in part (b) to draw the barge's load diagram.
- e. At what locations will the barge experience significant shear stress?
- f. What longitudinal bending condition with the barge experience in still water?

3. A rectangular, box-shaped barge has the following dimensions:

Length = 300 ft  
 Beam = 50 ft  
 Draft when empty = 5 ft

The empty barge is then loaded with containers. The containers are loaded as shown below.

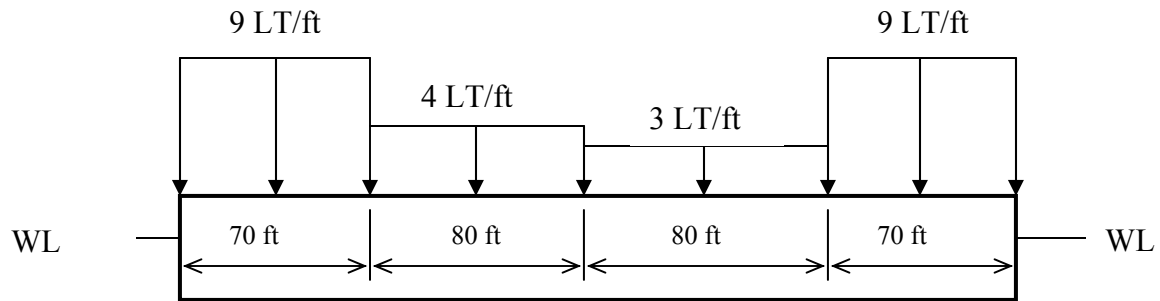

- Calculate the barge's displacement when empty.
  - Assuming the barge's structure is a homogeneous, calculate the distributed weight of the empty barge.
  - Calculate the barge's displacement when loaded.
  - Calculate the uniformly distributed buoyant force acting on the barge when the barge is loaded.
  - Based on your results from parts (b) and (d), draw the barge's load diagram.
  - In calm water, what longitudinal bending condition will the barge experience?
  - At what points will the barge experience significant shear stress?
- On a profile sketch of a ship, show a wave that results in sagging and the areas of the ship that are in tension and compression.
  - On a profile sketch of a ship, show a wave that results in hogging and the areas of the ship that are in tension and compression.
  - Box-shaped barges have a uniformly distributed buoyant force. Explain why destroyers (and most other hull forms) do not have a uniformly distributed buoyant force. What problem does this non-uniform distribution of buoyant force pose to the designer?

7. A 100 ft long box-shaped barge is loaded with gravel as shown below. The interior of the barge is uniformly loaded up to the deck. The combined weight of the barge's internal load and structure is 2 LT/ft. Once the level of the deck is reached, the load varies linearly to a maximum load of 12 LT at amidships.

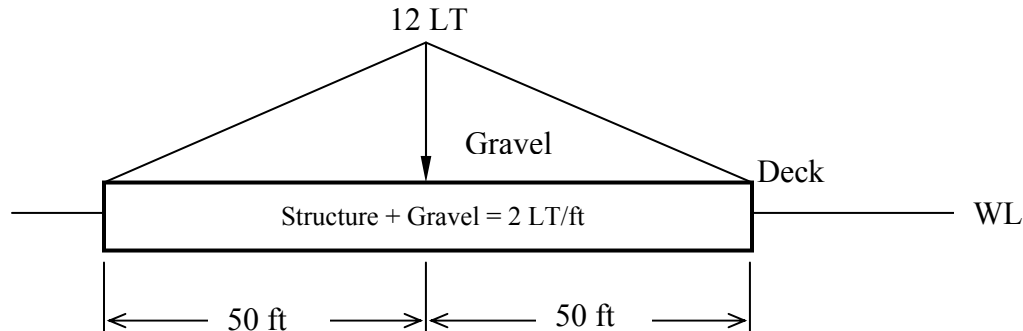

- Calculate the barge's displacement.
  - Draw a diagram representing the barge's displacement as a distributed force.
  - Calculate the barge's distributed buoyant force. Is the buoyant force uniformly distributed? Why or why not?
  - Calculate and draw the barge's load diagram.
  - At what points will the barge experience significant shear stress?
  - What longitudinal bending condition will the barge experience in calm water?
8. Sketch a section of a ship whose neutral axis is approximately 65% of the depth up from the keel. Use the elastic flexure formula to answer the following questions:
- What is the magnitude of bending stress at the neutral axis?
  - With the neutral axis located 65% of the depth up from the keel, which portion of this section will experience the greatest magnitude of bending stress?
  - Draw a diagram showing how the magnitude of bending stress varies from the deck to the keel. Assume the ship is in a sagging condition.
9. Using an appropriate diagram, show why significant shear stresses develop between the hull and superstructure if expansion joints are not used.

## Section 6.3

### Framing Systems

10. What is the purpose of transverse elements in a ship's framing system? What types of ship are likely to have more transverse elements than longitudinal elements?
11. What is the purpose of longitudinal elements in a ship's framing system? What types of ship are likely to have more longitudinal elements than transverse elements?
12. What type of framing system do most Naval vessels use? Why?
13. If longitudinal bending moments are the major load on ship structures, explain why the stringers are usually smaller than the deck girders and longitudinals. What advantage do small stringers have over stringers that are sized similarly to the deck girders?
14. The magnitude of bending stress in the keel is usually the maximum bending stress that a ship's section will experience. Since the magnitude of bending stress is independent of material properties, why would a keel made of steel with a yield stress of 80,000 psi be more advantageous than a keel made of steel with a yield stress of 60,000 psi?
15. When a 5" 54 caliber naval gun fires, large recoil forces are exerted on a ship's structure. What material properties are desirable for the ship's structure to absorb the gun's recoil?
16. In addition to large bending stresses, the flight deck of an aircraft carrier is subjected to other large loads. What type of loadings would the flight deck experience, and what material properties would be desirable when selecting a material for the construction of the flight deck?
17. Watertight bulkheads are an integral part of a ship's structure. In addition to providing stiffness to the hull, what other types of structural loads would a watertight bulkhead be subject to?

## Section 6.4

### Structural Failure Modes

18. List four common modes of structural failure on a ship.
19. What is fatigue of a material? Name four factors which make a ship more susceptible to fatigue failure.
20. Describe the effects of material type, temperature, geometry, and rate of loading on brittle fracture.
21. Why is ductility a desirable property when selecting a material for a ship's structure?



22. A ship is being designed for use in the Arctic Ocean. To prevent structural failure, what factors should be taken into account when selecting a material to be used for the hull plating? Frame your answer in terms of strength, ductility, toughness, etc. Would your material selection criteria change if the ship were to be used exclusively in the Java Sea?
23. A simply supported steel I-beam, 20 ft in length, is supporting a 10,000 lb load as shown below. The steel has the following material properties:

$$E = 30 \times 10^6 \text{ psi}$$

$$\sigma_Y = 40,000 \text{ psi}$$

$$\sigma_{UTS} = 65,000 \text{ psi}$$

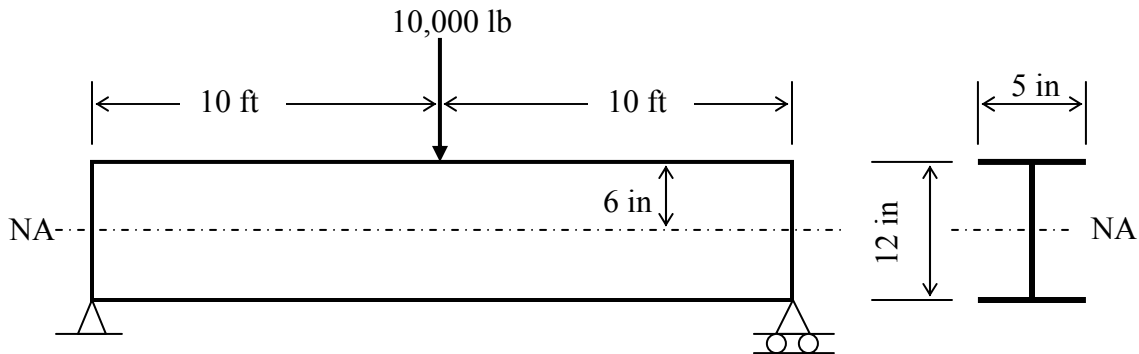

- Calculate the vertical reaction forces at each end of the beam.
- At its current loading condition, the beam is experiencing a bending moment of 100,000 ft-lb at its mid-point. The beam's second moment of area about its neutral axis is  $305 \text{ in}^4$ . Calculate the magnitude of bending stress at the top of the beam. Is the beam in tension or compression at this point?
- Is the current design adequate to prevent failure?
- Design specifications require that bending stress be  $\frac{1}{2}$  the yield stress. Is the design adequate to meet this requirement? If not, what can be done to meet design specifications?
- If the beam were constructed of a different material, how would this change the magnitude of bending stress?
- What failure mode will occur if the magnitude of bending stress exceeds yield stress?

24. A box-shaped oil barge is in the design process. The barge has a length of 325 ft, a depth of 15 ft, and a beam of 50 ft. When empty, the barge has a draft of 5 ft. When fully loaded, the barge has a draft of 10 ft. Your task is to select the material used to build the barge's structure. You have been given three materials to choose from. The material properties of each material are listed below.

Material #1:  $E = 30 \times 10^6$  psi  
 $\sigma_Y = 47,000$  psi  
 $\sigma_{UTS} = 71,000$  psi  
endurance limit = 34,000 psi at infinite life  
weight density = 490 lb/ft<sup>3</sup>  
cost: 7 cents per pound

Material #2:  $E = 30 \times 10^6$  psi  
 $\sigma_Y = 80,000$  psi  
 $\sigma_{UTS} = 100,000$  psi  
endurance limit = 48,000 psi at infinite life  
weight density = 490 lb/ft<sup>3</sup>  
cost: 17 cents per pound

Material #3:  $E = 10.4 \times 10^6$  psi  
 $\sigma_Y = 40,000$  psi  
 $\sigma_{UTS} = 47,000$  psi  
endurance limit = 14,000 psi at  $5 \times 10^8$  cycles  
weight density = 175 lb/ft<sup>3</sup>  
cost: 13 cents per pound

- a. What is the barge's displacement (LT) in salt water when empty? Note: when empty, the barge's weight is the weight of its structure only. The structural weight can be considered as uniformly distributed along the barge's length.
- b. What are some advantages and disadvantages of each material?
- c. What other information would you desire about each material before making a selection?
- d. Which material would you choose for the ship's structure?
- e. In order to prevent yield failure, one design specification requires that the maximum magnitude of bending stress be less than one half the yield strength of the material selected. Currently, calculations indicate that the magnitude of maximum bending stress is 42,000 psi. What can be done to reduce the magnitude of bending stress to an acceptable level?